

UNO

18110

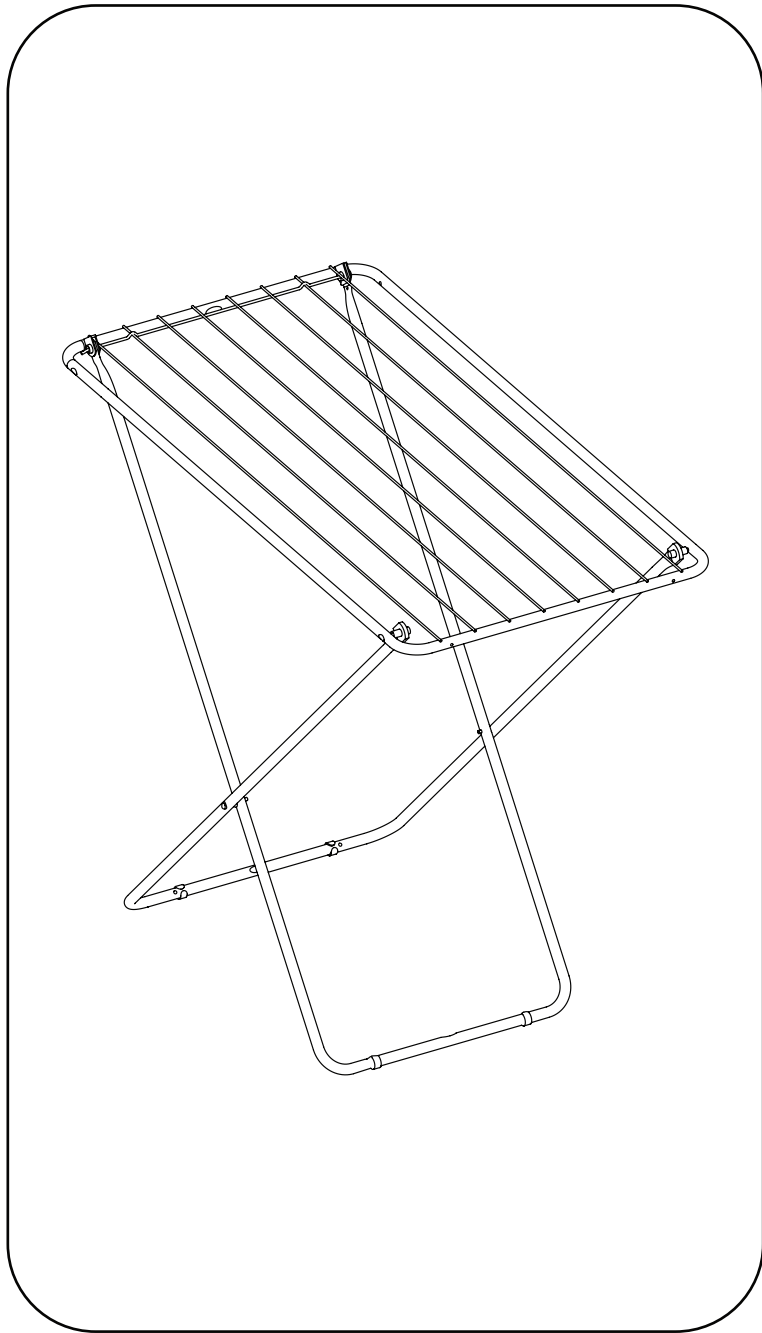

- Electrostatic powder coating
- Strong and durable steel frame
- Sliding mechanism that facilitates opening and closing
- Corner plastics on legs that prevent slipping
- 10 m hanging capacity
- 10 kg carrying capacity

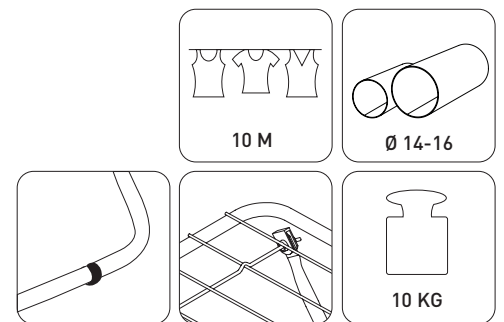

106x54,5x92,5	10	55x128	2,1	0,0174825
14-16	6	13,5x129,5x60	0,10489	13,75